

System No. C-AJ-8113

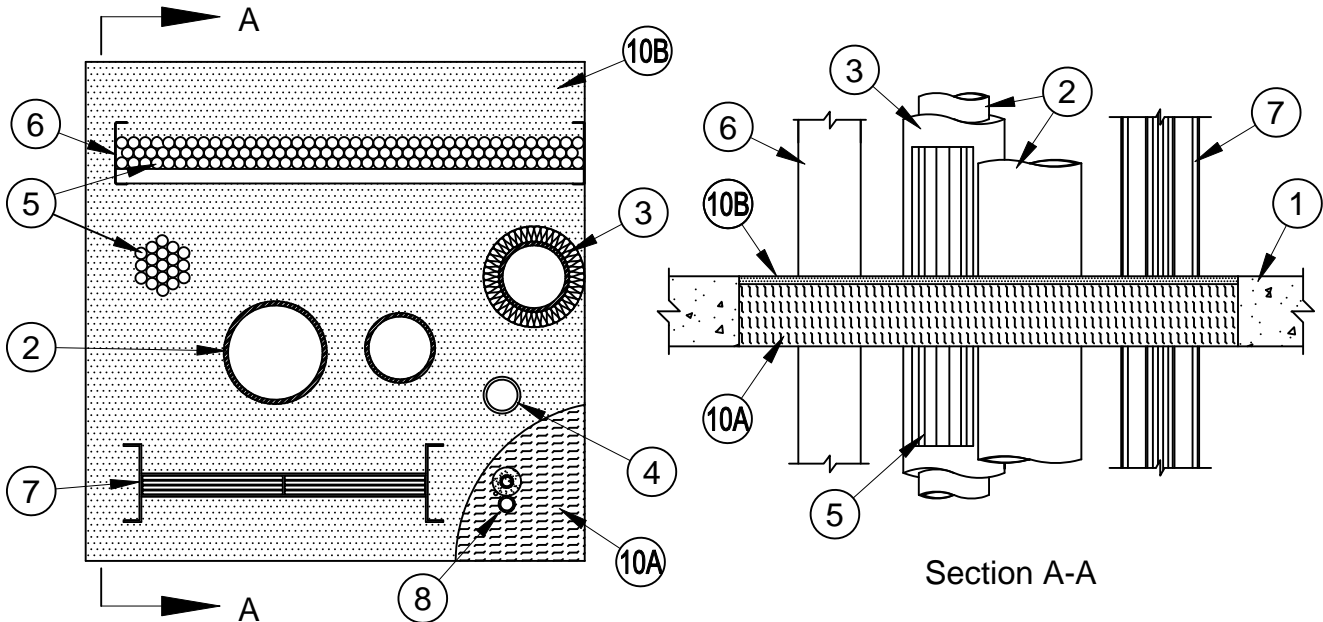

ANSI/UL1479 (ASTM E814)	CAN/ULC S115
F Rating - 2 Hr	F Rating - 2 Hr
T Rating - 0, 1/4, 1/2, 3/4 and 2 Hr (See Items 2 through 9)	FT Rating - 0, 1/4, 1/2, 3/4 and 2 Hr (See Items 2 through 9)
	FH Rating - 2 Hr
	FTH Rating - 0, 1/4, 1/2, 3/4 and 2 Hr (See Items 2 through 9)



1. **Floor or Wall Assembly** - Min 4-1/2 in. (114 mm) thick reinforced lightweight or normal weight (100-150 pcf or 1600-2400 kg/m³) concrete. Wall may also be constructed of any UL Classified **Concrete Blocks***. Max area of opening is 1024 sq in. (0.66 m²) with a max height of 32 in. (813 mm) when installed in a wall or a max width of 32 in. (813 mm) when installed in a floor.
See **Concrete Blocks** (CAZT) category in the Fire Resistance Directory for names of manufacturers.
2. **Metallic Penetrants** - One or more metallic pipes, conduits or tubes to be installed within the opening. Annulus between penetrants is min 0 in. (point contact) to max 24 in. (609 mm). Annulus between penetrants and periphery of opening is 0 in. (point contact) to max 24 in. (609 mm). Penetrants rigidly supported on both sides of floor or wall assembly. The following types and sizes of metallic pipes, conduits or tubing may be used:
 - A. **Steel Pipe** - Nom 12 in. (305 mm) diam (or smaller) Schedule 10 (or heavier) steel pipe.
 - B. **Iron Pipe** - Nom 12 in. (305 mm) diam (or smaller) cast or ductile iron pipe.
 - C. **Conduit** - Nom 6 in. (152 mm) diam (or smaller) rigid steel conduit, nom 4 in. (102 mm) diam (or smaller) electrical metallic tubing (EMT), or nom 4 in. (102 mm) diam (or smaller) steel Flexible Metal Conduit#.
 - D. **Copper Pipe or Tube** - Nom 6 in. (152 mm) diam (or smaller) Regular (or heavier) copper pipe or Type M (or heavier) copper tube.



Specified Technologies Inc. 210 Evans Way Somerville, NJ 08876

Reproduced courtesy of Underwriters Laboratories, Inc.
Created or Revised: June 19, 2014



Type of Metallic Penetrant	Max Dim of Through Penetrants, In.(mm)	T Rating, Hr
Steel or Iron Pipe, Conduit	12 (305)	0
Copper Pipe or Tube	6 (152)	0
Steel or iron Pipe, Conduit or EMT	4 (102)	1/4
Steel or iron Pipe, Conduit or EMT	2 (51)	1/2
Steel or iron Pipe, Conduit or EMT	1(25)	3/4

- 2A1. **Firestop Device*** - (Optional, Not Shown) - When used in conjunction with Item 2A, 2B, or 2C, single layer of coolant wrap provided with collar to be continuously wrapped around the outer circumference of each penetrant and temporarily held in place with tape. Edge of coolant wrap to be offset from the surface of floor or both sides of the wall in order to allow for installation of restraining collar. Restraining collar to be installed such that an edge is flush with top surface of the floor or both surfaces of wall and coolant wrap is nominally centered within pocket of restraining collar. Restraining collar to overlap itself by min 1/8 in. (3 mm) and secured in place around penetrant with nom 1/2 in. (13 mm) wide stainless steel hose clamps nominally centered on both flanges. Min clearance between pipes to be 2-1/2 in. (64 mm). **When Item 2A1 is used, the maximum hourly T Rating is 2 Hr for penetrants 4 in. (102 mm) diam (or smaller).**

SPECIFIED TECHNOLOGIES INC - SpecSeal T-Collar

3. **Pipe Insulation** - One or more max 4 in. (102 mm) metallic pipes or tubes may be insulated. Annulus between penetrants is min 0 in. (point contact) to max 24 in. (609 mm). Annulus between penetrants and periphery of opening is 1-1/2 in. (38 mm) to max 24 in. (609 mm). Penetrants rigidly supported on both sides of floor or wall assembly. The following types of pipe insulation may be used:

- A. **Pipe and Equipment Covering Materials*** - Nom 1 in. (25 mm) thick hollow cylindrical heavy density (min 3.5 pcf or 56 kg/m³) glass fiber units jacketed on the outside with an all service jacket. Longitudinal joints sealed with metal fasteners or factory-applied self-sealing lap tape. Transverse joints secured with metal fasteners or with butt tape supplied with the product. **When Item 3A is used, T Rating is 3/4 Hr.**

See Pipe and Equipment Covering Materials (BRGU) category in the Building Materials Directory for names of manufacturers. Any pipe covering meeting the above specifications and bearing the UL Classification Marking with a Flame Spread Index of 25 or less and a Smoke Developed Index of 50 or less may be used.

- B. **Pipe Covering Materials*** - Nom 2 in. (51 mm) thick unfaced mineral fiber pipe insulation having a nom density of 3.5 pcf (56 kg/m³) (or heavier) and sized to the outside diam of the pipe or tube. Pipe insulation secured with min 8 AWG steel wire spaced max 12 in. (305 mm) OC. **When Item 3B is used, T Rating is 2 Hr.**

IIG MINWOOL L L C - High Temperature Pipe Insulation 1200, High Temperature Pipe Insulation BWT and High Temperature Pipe Insulation Thermaloc

- C. **Sheathing Material*** - Use in conjunction with Item 3B. Foil-scrim-kraft or all service jacket material shall be wrapped around the outer circumference of the pipe insulation (Item 3B) with the kraft side exposed. Longitudinal and transverse joints sealed with metal fasteners or butt tape.

See Sheathing Materials (BVDV) category in the Building Materials Directory for names of manufacturers. Any sheathing material meeting the above specifications and bearing the UL Classification Marking with a Flame Spread Index of 25 or less and a Smoke Developed Index of 50 or less may be used.

- D. **Tube Insulation-Plastics##** - Nom 3/4 in. (19 mm) thick acrylonitrile butadiene/polyvinyl chloride (AB/PVC) flexible foam furnished in the form of tubing. **When Item 3D is used, T Rating is 1/2 Hr.**

See Plastics (QMFZ2) category in the Plastics Recognized Component Directory for names of manufacturers. Any Recognized Component tube insulation meeting the above specifications and having a UL 94 Flammability Classification of 94-5VA may be used.

- E. **Pipe Covering Materials* - Cellular Glass Insulation** - Nom 2 to 3 in. (51 to 76 mm) thick cellular glass units sized to the outside diam of the pipe or tube and supplied in nom 24 in. (610 mm) long half sections or nom 18 in.(457 mm) long segments. Pipe insulation installed on pipe in accordance with the manufacturer's instructions. **When Item 3E is used, T Rating is 2 Hr.**

PITTSBURGH CORNING CORP - FOAMGLAS



Specified Technologies Inc. 210 Evans Way Somerville, NJ 08876

Reproduced courtesy of Underwriters Laboratories, Inc.

Created or Revised: June 19, 2014

(800)992-1180 • (908)526-8000 • FAX (908)231-8415 • E-Mail:techserv@stifirestop.com • Website:www.stifirestop.com



C-AJ-8113
PAGE 2 OF 4

- F. **Metal Jacket** - Used in conjunction with Item 3E. Min 12 in. (305 mm) long jacket formed from min 0.010 in. (0.25 mm) thick aluminum sheet cut to wrap tightly around the pipe insulation with a min 2 in. (51 mm) lap and secured using bands and seals of a similar material or min No. 18 AWG steel tie wire. Bands or steel tie wire to be located within 2 in. (51 mm) of each end of the jacket and spaced max 10 in. (254 mm) OC. Jacket installed with edge abutting surface of fill material (Item 9A) on top surface of floor or both surfaces of wall. Metal jacket to be used in addition to any other jacketing material which may be required on the pipe covering.
- G. **Pipe and Equipment Covering Materials*** - Nom 2 to 3 in. (51 to 76 mm) thick hollow cylindrical calcium silicate (min 14 pcf or 224 kg/m³) units sized to the outside diam of the pipe or tube. Pipe insulation secured with stainless steel bands or min 8 AWG stainless steel wire spaced max 12 in. (305 mm) OC. **When Item 3G is used, T Rating is 2 Hr.**
4. **Nonmetallic Penetrants** - One or more nonmetallic pipes, conduits or tubes to be installed within the opening. Annulus between penetrants and periphery of opening is min 1 in. (25 mm) to max 24 in. (609 mm). Separation between metallic and nonmetallic penetrants is min 6 in. (152 mm). Penetrants rigidly supported on both sides of floor or wall assembly. The following types and sizes of nonmetallic pipes, conduits or tubing may be used:
- A. **Polyvinyl Chloride (PVC) Pipe** - Nom 2 in. (51 mm) diam (or smaller) solid or cellular core Schedule 40 PVC pipe for use in closed (process or supply) or vented (drain, waste or vent) piping systems.
 - B. **Chlorinated Polyvinyl Chloride (CPVC) Pipe** - Nom 2 in. (51 mm) diam (or smaller) SDR13.5 CPVC pipe for use in closed (process or supply) piping systems.
 - C. **Rigid Nonmetallic Conduit+** - Nom 2 in. (51 mm) diam (or smaller) Schedule 40 PVC conduit installed in accordance with the National Electrical Code (NFPA 70).
 - D. **Electrical Nonmetallic Tubing (ENT)+** - Nom 2 in. (51 mm) diam (or smaller) corrugated wall ENT formed of polyvinyl chloride (PVC) installed in accordance with the National Electrical Code (NFPA 70).
 - E. **Optical Fiber Raceway+** - Nom 2 in. (51 mm) diam (or smaller) optical fiber raceway (innerduct). Optical fiber raceway installed in accordance with Article 770 of the National Electrical Code (NFPA 70).
- When Item 4 is used, the T Rating of the firestop system is 2 hr.**
5. **Cables** - Nom 4 in. (102 mm) diam (or smaller) tight bundle of cables. Annulus between cable bundle and periphery of opening is min 0 in. (point contact) to max 24 in. (609 mm). Separation between cable bundle and metallic or nonmetallic penetrants shall be min 6 in. (152 mm). Cable bundle rigidly supported on both sides of floor or wall assembly. The following types and sizes of cables may be used:
- A. Max 1/C - 1000 kcmil cable with polyvinyl chloride (PVC) or cross-linked polyethylene (XLPE) insulation and jacket.
 - B. Max 7/C - No. 12 AWG cable with PVC-nylon insulation and PVC jacket.
 - C. Max 400 pair - No. 24 AWG copper conductor telephone cable with PVC insulation and jacket.
 - D. Max RG/U coaxial cables with fluorinated ethylene jacket and insulation.
 - E. Multiple fiber optic cables with PVC insulation.
- F. **Through Penetrating Products*** - Max 4/C with ground No. 2/O AWG **Metal-Clad Cable+**.

AFC CABLE SYSTEMS INC

When cables are used, T Rating is 1/2 hr.

6. **Cable Tray** - Max 30 in. (762 mm) wide by max 6 in. (152 mm) deep open ladder cable tray with channel-shaped side rails formed from min 0.060 in. (1.5 mm) thick (No. 16 MSG) galv steel or min 0.060 in. (1.5 mm) thick aluminum with rungs spaced max 9 in. (229 mm) OC. A max of two cable trays may be installed within the opening with a min separation of 8 in. (203 mm) between trays. Annulus between the cable tray and the periphery of the opening is min 0 in. (point contact) to max 24 in. (609 mm). Separation between cable tray and metallic or nonmetallic penetrants is min 6 in. (152 mm). Cable trays to be rigidly supported on both sides of the floor or wall assembly. Aggregate cross-sectional area of cables in cable tray not to exceed 40 percent of the cross-sectional area of the cable tray based on a max 3 in. (76 mm) cable loading depth within tray. Any combination of the cable types specified in Item 5 may be used. **When cable tray is used, T Rating is 1/2 hr.**
7. **Busway+** - Nom 19 in. (483 mm) wide (or smaller) by 6 in. (152 mm) deep "I" shaped aluminum enclosure containing factory-mounted copper bars rated for 600 V, 5000 A or max 26 in. (660 mm) wide by max 6 in. (152 mm) deep "I" shaped aluminum enclosure containing factory-mounted aluminum bars rated for 600 V, 4000 A. . A max of two busways may be installed within the opening. The annular space between the busway and the periphery of the opening shall be a min 0 in. (point contact) to a max 24 in. (609 mm). Busways spaced min 6 in. (152 mm) from all other penetrants. Busway to be rigidly supported on both sides of floor or wall assembly. The busway shall bear the UL Listing Mark and shall be installed in accordance with all provisions of the National Electrical Code, NFPA 70. **When busway is used, the T Rating is 1/4 hr.**



Specified Technologies Inc. 210 Evans Way Somerville, NJ 08876

Reproduced courtesy of Underwriters Laboratories, Inc.
Created or Revised: June 19, 2014

(800)992-1180 • (908)526-8000 • FAX (908)231-8415 • E-Mail:techserv@stifirestop.com • Website:www.stifirestop.com



C-AJ-8113
PAGE 3 OF 4

8. **Air Conditioning (AC) Line Set** - One or more AC line sets installed within opening. Each AC line set consists of two pipes or tubes (Item 8A), tubing insulation (Item 8B) and a thermostat cable (Item 8C). The space between the AC line sets shall be min 2 in. (51 mm). The space between the AC line sets and the periphery of the opening shall be min 0 in. (point contact) to max 24 in. (609 mm). The AC line sets shall be spaced min 6 in. from uninsulated metallic penetrants and shall be rigidly supported on both sides of the floor or wall assembly.
- 8A. **Through Penetrant** - A max of two pipes or tubes to be installed in each AC line set. Of the two pipes or tubes, only one may have a nom diam greater than 1/2 in. (13 mm). The following types and sizes of through penetrants may be used:
- A. **Steel Pipe** - Nom 1 in. (25 mm) diam (or smaller) Schedule 5 (or heavier) steel pipe.
 - B. **Iron Pipe** - Nom 1 in. (25 mm) diam (or smaller) cast or ductile iron pipe.
 - C. **Copper Pipe** - Nom 1 in. (25 mm) diam (or smaller) Regular (or heavier) copper pipe.
 - D. **Copper Tube** - Nom 1 in. (25 mm) diam (or smaller) Type L (or heavier) copper tube.
- 8B. **Tube Insulation - Plastics#** - Nom 3/4 in. (19 mm) thick acrylonitrile butadiene/polyvinyl chloride (AB/PVC) flexible foam furnished in the form of tubing. The tube insulation may be installed on one max 3/4 in. (19 mm) diam pipe or tube in each AC line set. The space between the insulated and uninsulated pipes or tubes within each AC line set shall be 0 in. (point contact).
- See **Plastics** (QMFZ2) category in the Plastics Recognized Component Directory for names of manufacturers. Any Recognized Component tube insulation meeting the above specifications and having a UL 94 Flammability Classification of 945VA may be used.
- 8C. **Cable** - One 4 pair No. 18 AWG (or smaller) thermostat cable with polyvinyl chloride (PVC) insulation and jacket materials may be installed with each AC line set.

When Item 8 is used, the T Rating of the firestop system is 1/4 hr.

9. **Steel Duct** - (Not Shown) Nom 12 in. (305 mm) diameter (or smaller) No. 30 GA (or heavier) steel duct installed within opening when opening contains no cables or cable tray. A max of two steel ducts may be installed within the through-opening. Ducts to be spaced min 4 in. (102 mm) apart and min 8 in. (203 mm) from insulated penetrants and nonmetallic penetrants. Annulus between the steel duct and the periphery of the opening shall be min 0 in. (point contact) to max 24 in. (0 to 609 mm). Steel ducts to be rigidly supported on both sides of floor or wall assembly. **When steel duct is used, the T Rating is 0 hr.**
10. **Firestop System** - The firestop system shall consist of the following items:
- A. **Packing Material** - Min 4 in. (102 mm) thickness of min 4 pcf (64 kg/m³) mineral wool batt insulation tightly packed into opening. Packing material recessed from top surface of floor assembly or from both surfaces of wall or precast concrete units to accommodate the required thickness of fill material.
 - B. **Fill, Void or Cavity Materials*-Sealant** - Min 1/2 in. (13 mm) depth of fill material applied within the annulus, flush with top surface of floor assembly or with both surfaces of the wall assembly. Additional fill material forced into interstices of grouped cables and grouped cables within cable trays. At point contact location between through penetrant and concrete, a min 3/8 in. (9.6 mm) diam of fill material shall be applied at through penetrant/concrete interface on top surface of floor or both surfaces of the wall.

SPECIFIED TECHNOLOGIES INC - SpecSeal Series SSS Sealant or SpecSeal LCI Sealant

* Indicates such products shall bear the UL or cUL Certification Mark for jurisdictions employing the UL or cUL Certification (such as Canada), respectively.

#Bearing the UL Recognized Components Mark

+Bearing the UL Listing Mark



Specified Technologies Inc. 210 Evans Way Somerville, NJ 08876

Reproduced courtesy of Underwriters Laboratories, Inc.

Created or Revised: June 19, 2014

(800)992-1180 • (908)526-8000 • FAX (908)231-8415 • E-Mail:techserv@stifirestop.com • Website:www.stifirestop.com



C-AJ-8113
PAGE 4 OF 4